

HB3914AESR/CESR

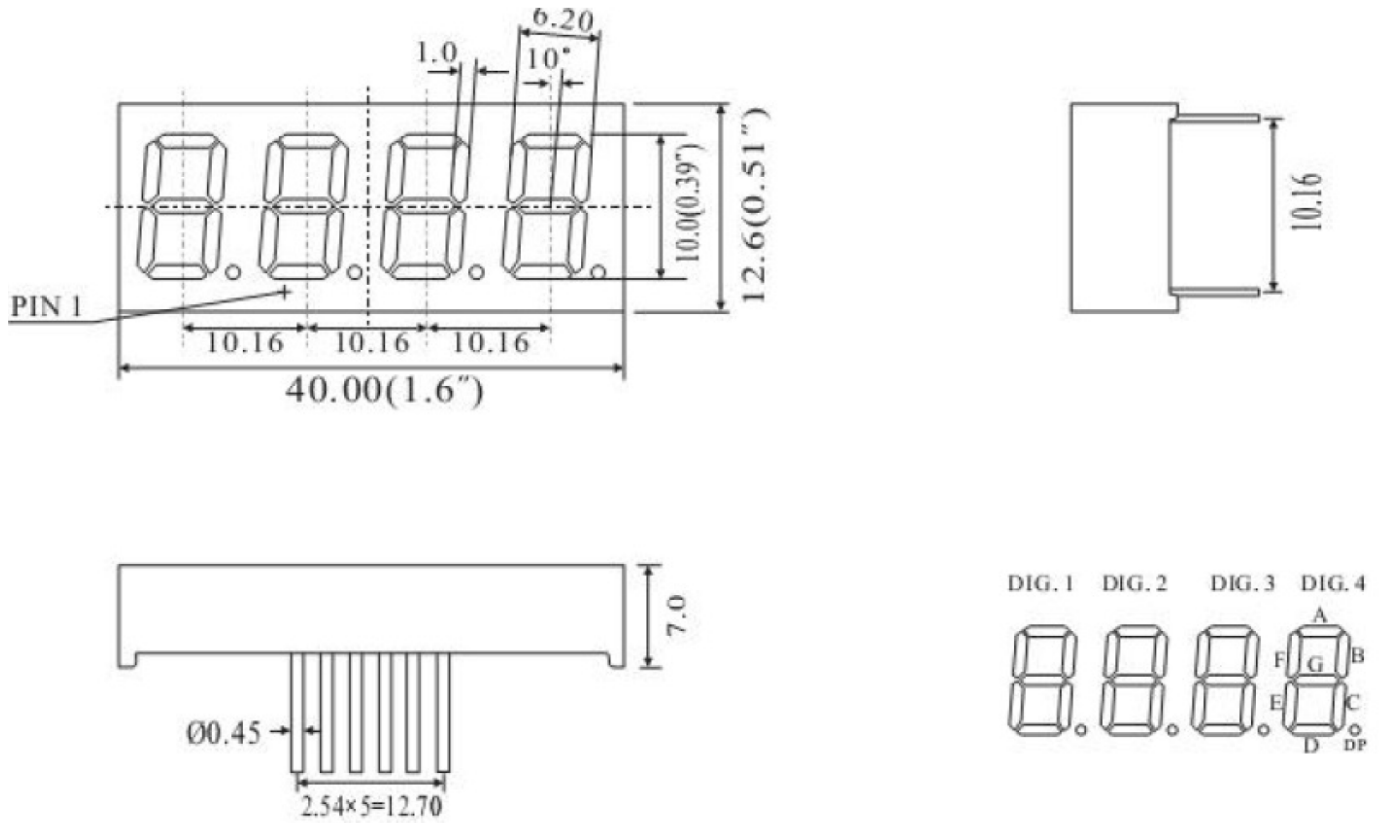

UNIT: MM(INCH) TOLERANCE: ±0.25(0.01")

HB3914CESR

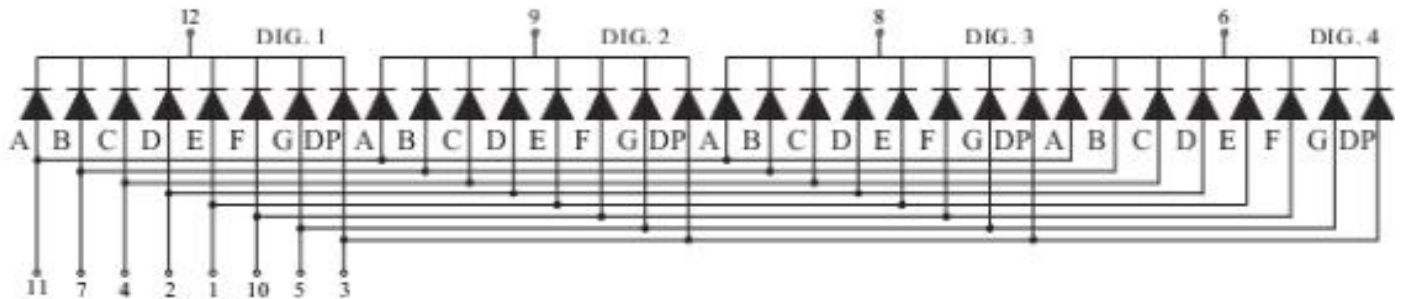

HB3914AESR

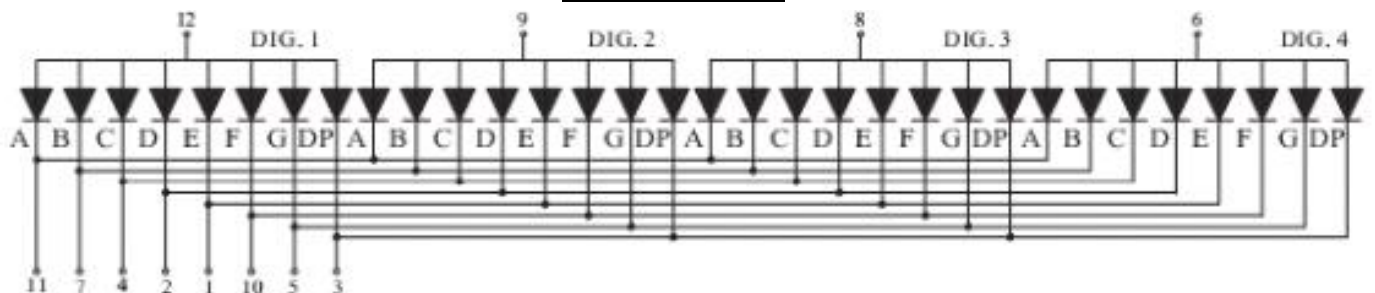

HB3914AESR/CESR

## DESCRIPTION

- 10.00mm (0.39") four digits display series, common anode
- Standard brightness.
- Low current operation.
- Excellent character appearance.
- Easy mounting on P.C. boards or sockets.

产品最大绝对参数值 Absolute maximum ratings (Ta=25°C)

每段参数 PARAMETER PER SEGMENT	符号 SYMBOL	最大数 MAX	单位 UNIT
反向电压 Reverse Voltage	VR	5	V/Seg
正向电流 Forward Current	IF	20	mA/Seg
峰值电流 (0.1ms) Peak Forward current (1/10 Duty Cycle)	IPEAK	120	mA/Seg
功耗 Power Dissipation	PA	40	mW/Seg
工作条件温度 Operating Temperature Range		-25°C to +85°C	
储存温度 Storage Temperature Range		-30°C to +85°C	
距离胶体 1.6mm 焊接, 温度 260°C, 焊接时间最多 3 秒 Lead soldering Temperature 260°C at 1.6mm Form Body For 3 Seconds			

产品光电参数值 ELECTRICAL/OPTICAL CHARACTERISTICS (Ta=25°C)

参数 PARAMETER	符号 SYMBOL	MIN	TYP	MAX	UNIT	测试条件 Test condition
每段亮度 Luminous Intensity Per Segment	Iv	90	98	105	mcd	IF=20mA
每段正向电压 Forward Voltage Per segment	VF	2.0	2.05	2.1	V	IF=20mA
波长 Wavelength	$\lambda_p / \lambda_d$		629/625		nm	IF=20mA
半波长度 Spectrum width of half value	$\Delta \lambda$		20		nm	IF=20mA
每段反向电流 Reverse Current Per Segment	IR			10	$\mu A$	VR=5V

器件表面及封装颜色 Surface / Lens color

Number	0	1	2	3	4
Ref Surface Color	White	Black	Gray	Red	Green
Epoxy Color	Water clear	White Diffused	Red Diffused	Green Diffused	Yellow Diffused

HB3914AESR/CESR

