

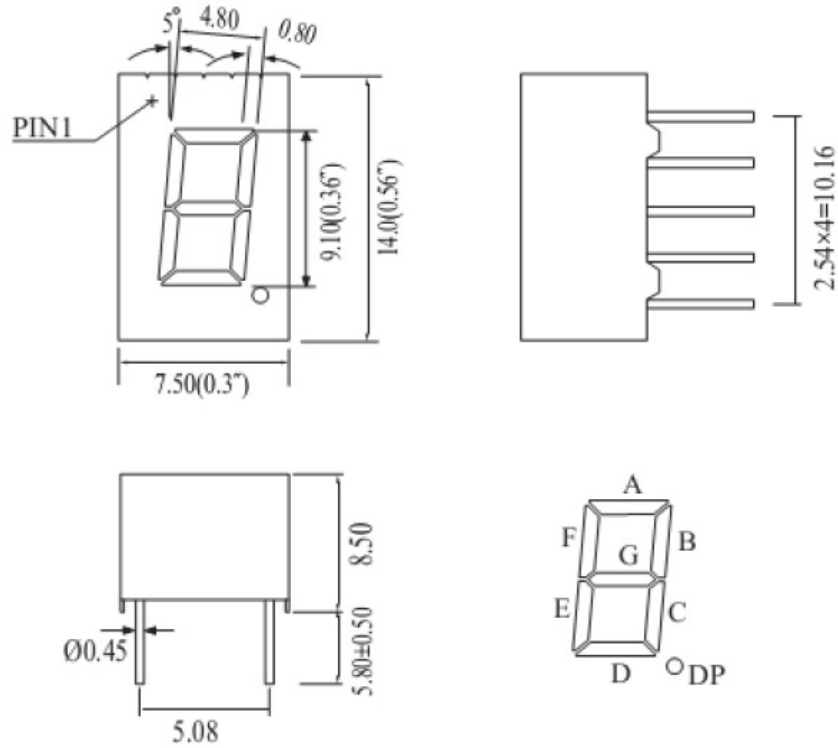

**HB3611ASR/CSR**



UNIT: MM(INCH) TOLERANCE:  $\pm 0.25(0.01)$ "

**Internal Circuit Diagram**

**HB3611ASR**

**HB3611CSR**

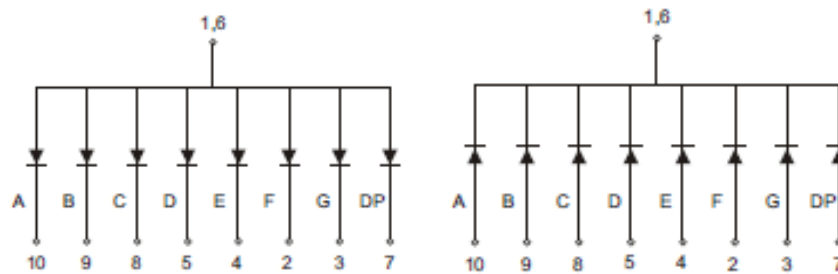



## HB3611ASR/CSR

### DESCRIPTION

- 9.10mm (0.36") single digits display series, common anode, black surface, white diffused
- Standard brightness.
- Low current operation.
- Excellent character appearance.
- Easy mounting on P.C. boards or sockets.

产品最大绝对参数值 Absolute maximum ratings (Ta=25°C)

每段参数 PARAMETER PER SEGMENT	符号 SYMBOL	最大数 MAX	单位 UNIT
反向电压 Reverse Voltage	VR	5	V/Seg
正向电流 Forward Current	IF	20	mA/Seg
峰值电流 (0.1ms) Peak Forward current(1/10 Duty Cycle)	IPEAK	60	mA/Seg
功耗 Power Dissipation	PA	42	mW/Seg
功耗 Power Dissipation	PA	42	mW/dot
工作条件温度 Operating Temperature Range		-25°C to +85°C	
储存温度 Storage Temperature Range		-30°C to +85°C	
距离胶体 1.6mm 焊接, 温度 260°C, 焊接时间最多 3 秒 Lead soldering Temperature 260°C at 1.6mm Form Body For 3 Seconds			

产品光电参数值 **ELECTRICAL/OPTICAL CHARACTERISTICS (Ta=25°C)**

参数 PARAMETER	符号 SYMBOL	MIN	TYP	MAX	UNIT	测试条件 Test condition
每段亮度 Luminous Intensity Per Segment	Iv	25	28	30	mcd	IF=20mA
每段正向电压 Forward Voltage Per segment	VF	1.95	2.0	2.1	V	IF=20mA
每段正向电压 Forward Voltage for Dot	VF	1.95	2.0	2.1	V	IF=20mA
波长 Wavelength	$\lambda_p / \lambda_d$		635/ 630		nm	IF=20mA
半波长度 Spectrum width of half value	$\Delta \lambda$		20		nm	IF=20mA
每段反向电流 Reverse Current Per Segment	IR			10	$\mu$ A	VR=5V

器件表面及封装颜色 **Surface / Lens color**

Number	0	1	2	3	4
Ref Surface Color	White	Black	Gray	Red	Green
Epoxy Color	Water clear	White Diffused	Red Diffused	Green Diffused	Yellow Diffused